

Fig. KFCUL25

FCU Valve Kit with PICV

PN25

Specification:

- Static Pressure Rating: PN25
- Working Medium: Water
- Temperature range: 0°C to 100°C (nominal pressure rating varies at different temperatures within the range)
- End connection:
 - Female (pipe end) (parallel)
 - Male (flexible hose end), (Taper)

Includes:

- Supplied complete with EPP insulation box
- PICV (for details see catalogue for PICV Model KBP25)
- 3 Isolating Ball valves with extended handles for allowance of insulation (1 for supply, 1 for return, 1 for by-pass)
- Built-in Strainer with stainless steel mesh and drain plug
- 2 Flexible hoses for connection to FCU (standard length of approximately 300mm)

Actuator Details:

- ON/OFF : 230V, NC
- Modulating : 24V, 0-10V DC, NC

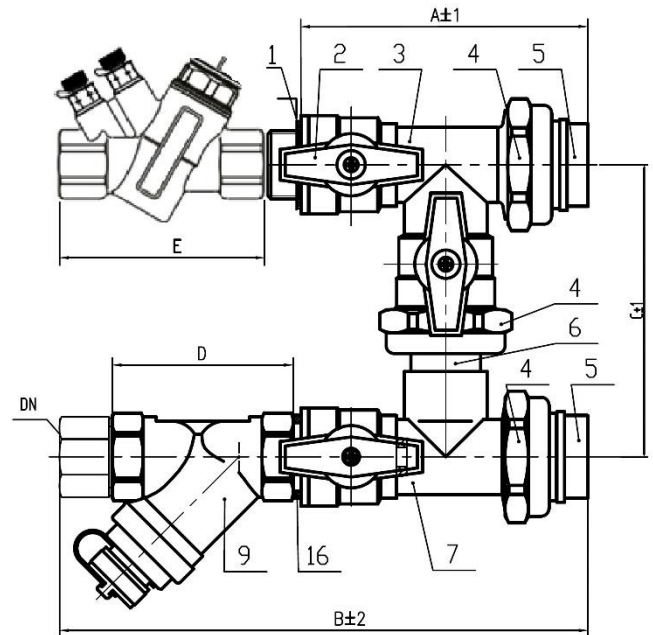

DIMENSIONS

DN	A	B	C	D	E
DN15	108	197	106	65	81
DN20	112	201	113	70	85
DN25	127	226	130	80	102

No.	Part	Material
1	Gasket	Silicon Rubber
2	Hand Wheel	Aluminum
3	Body	Brass CW602N
4	Hexagonal Nut	Brass CW602N
5	Female Adapter	Brass CW602N
6	Male Connector	Brass CW602N
7	Body	Brass CW602N
9	Strainer	Brass CW602N
10	Flexible Hoses	SS304
11	Hand Wheel Cover	Plastic
12	Hand Wheel Screw	SS304
13	Spacing Cover	ABS
14	Stem	Brass CW602N
15	Cap	Brass CW602N
16	Gasket	PTFE

Ball valve handle accessories

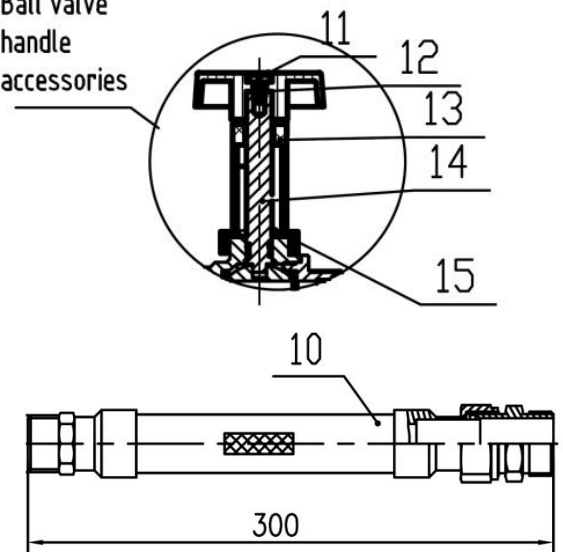

Mesh Details:

- Material: SS304
- Diameter of Hole: 0.8mm
- Thickness of Mesh: 0.5mm
- Free area percentage: about 52%
- Holes/cm²: 60